

LEO-S552-TP

LoRaWAN LCD Dual Temperature Probe Sensor



Features

- Food level PT100 temperature probes sensor
- IP65 waterproof enclosure with dust plug, suitable for harsh environment
- Support automated temperature monitoring and anti-tamper recording of data in compliance with HACCP, meeting the authenticity requirements of 21 CFR Part 11B electronic record
- Provide simplified PDF data export for easy documentation without complex paperwork
- Features low-consumption LCD display, enabling intuitive data reading
- Built-in 2 x 4000 mAh replaceable battery and long battery without replacement

Specifications

Frequency	US915/AU915/KR920/AS923/RU864/IN865/EU868/CN470	
NFC	Y (Configuration)	
Display	LCD Segment Code Screen	
Button	1 x Reset Button (Internal) 1 x Power/Switch Button (External)	
Power Supply	1. 2 x 4000 mAh battery (ER18505) 2. USB Type-C (5V/1A)	
Battery Life	2 years (10 min interval, @25°C)*	
Data Storage Capacity	10,000	
Working Temperature	-30°C ~ 70°C	
Working Humidity	0 ~ 95% (non-condensing) at 25°C (77°F)	
Wireless Range	100 meters+ (Line of Sight)*	
I/O	USB Type-C	
Dimension	109.35 x 75 x 29 mm (4.31 x 2.95 x 0.79 in)	
Weight	185g	
Certifications	FCC, CE	
Connection Type	3-wire connection	
Cable Length	1.5m	
Probe Type	Stainless steel 316	
Temperature	Measurement Range	-40 ~ 125 °C Option: -20 ~ 50 °C
	Accuracy Range	± 0.5 °C
	Resolution	0.1 °C

* Test under laboratory conditions and for guideline purposes only

Ordering Information

Part Number	Description
LEO-S552-TPG0	LEO-S LoRaWAN LCD Dual Temp Probe sensor 915
LEO-S552-TPC0	LEO-S LoRaWAN LCD Dual Temp Probe sensor 470
LEO-S552-TPE0	LEO-S LoRaWAN LCD Dual Temp Probe sensor 868

Packing List

- 2 x Mounting Kits
- 2 x Screw Caps
- 2 x PT100 Food Level Probe

Dimensions

Unit: mm

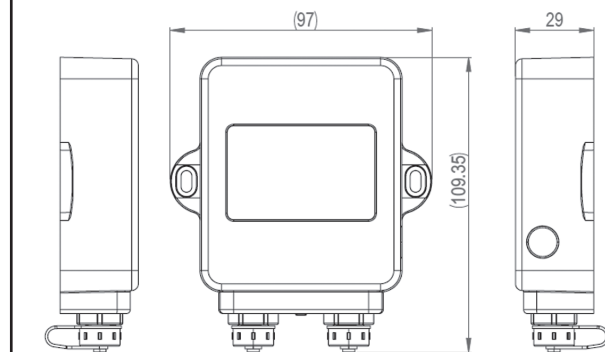

USM-S67

LoRaWAN & WIFI Gateway



Features

- Quad-core industrial processor with big memory
- Equip with SX1302 chip, handling a higher amount of traffic with lower consumption
- 8 half/full-duplex channels
- IP65 enclosure and industrial design for parts of outdoor environment applications like eaves
- Desktop, wall or pole mounting
- Multi backhaul backups with Ethernet and Wi-Fi
- Easy and centralized management of remote devices
- Enable security communication with multiple VPNs like IPsec/OpenVPN/L2TP/PPTP/DMVPN
- Built-in network server and MQTT/HTTP/HTTPS API for easily integration
- Embedded Python SDK for users secondary development
- Fast and user-friendly programming by Node-RED development tool

Specifications

General	CPU	Quad-core 1.5 GHz, 64-bit ARM Cortex-A53
	Memory	512 MB DDR4
	Flash	8 GB eMMC
	LED Indicators	1 x POWER, 1 x STATUS, 1 x LoRa, 1 x Wi-Fi, 1 x Ethernet
LoRaWAN	Frequency	US915/AU915/KR920/AS923/RU864/IN865/EU868/CN470
	Antenna	2 x Internal Antennas 1 x External Antenna
	Wireless Range	100 meters+ (Line of sight)**
	Connect Q'ty	Support up to 100 x LEO-S sensors*
Connectivity	Ethernet	10/100/1000 Base-T
	Wifi	IEEE 802.11 b/g/n, 2.4GHz
Others	Button	1 x Reset Button
	Power	1. DC Jack Connector for 9-24 V _{DC} power supply 2. 1 x 802.3 af PoE input
	Working Temperature	-40 ~ 70°C (-40 ~ 158°F)
	Storage Temperature	-40 ~ 85°C (-40 ~ 185°F)
	Operating Humidity	0 ~ 95% (non-condensing) at 25°C (77°F)
	dimension	180 x 110 x 56.5 mm (7.09 x 4.33 x 2.22 in)
	IP	65
Certification	FCC, TELEC, CE, KC, RCM, SIRIM, NBTC	

* Dependent on usage scenario

** Test under laboratory conditions and for guideline purposes onl

Dimensions

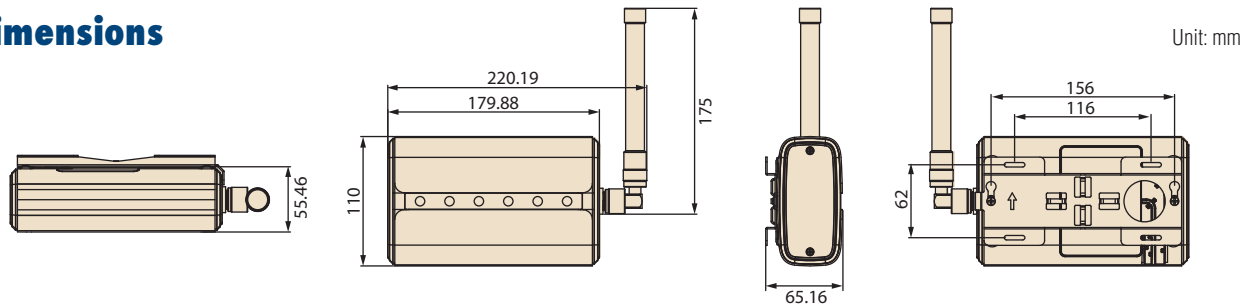

Ordering Information

Part Number	Description
USM-S67-GOWPO	USM-S67 LoRaWAN & WIFI Gateway 915
USM-S67-COWPO	USM-S67 LoRaWAN & WIFI Gateway 470
USM-S67-EOWPO	USM-S67 LoRaWAN & WIFI Gateway 868

Packing List

- 1 x LAN Cable(1.5M)
- 1 x Adapter
- 1 x Mounting Bracket
- 2 x Mounting Kits
- 1 x LoRaWAN Antenna

USM-S67

LoRaWAN & LTE Compact Gateway



Features

- Compact LoRaWAN LTE Gateway
- 8 half-duplex channels
- Small in size for easy carrying & deployment
- Desktop, wall or ceiling mounting support
- Multi backhaul backups with Ethernet and Cellular (4G)
- High cost performance, suitable for small applications
- Compatible with mainstream network servers like The Things Industries, ChirpStack, AWS IoT Core for LoRaWAN® and etc.

Specifications

General	CPU	Dual-core 240MHz, 32-bit Xtensa® LX7	
	Memory	8 MB PSRAM	
	Flash	16 MB Flash	
	LED Indicators	1 x SYSTEM, 1 x LTE	
LoRaWAN	Frequency	US915/AU915/KR920/AS923	
	Antenna	2 x External Antennas	
	Wireless Range	100 meter+ (Line of sight)**	
	Connect Q'ty	Support up to 20 pcs*	
Connectivity	Ethernet	10/100 Base-T	
	LTE	CAT.1 / GSM	
	Cellular Band	EU Band:	LTE-FDD: B1/2/3/4/5/7/8/12/13/17/18/ 19/20/25/26/28/66
			LTE-TDD: B34/38/39/40/41; GSM: B2/3/5/8
Others	Button	1 x Reset Button	
	Power	1. 5V/2A by Type-C Port 2. 5~12 V _{DC}	
	Power Consumption	Typical 1.3W, Max 3.1 W	
	Working Temperature	-20°C ~ 50°C (-4°F ~ 122°F)	
	Storage Temperature	-40°C ~ 85°C (-40°F ~ 185°F)	
	Dimension	Ø 115 x 21 mm (Ø 4.52 x 0.83 in) (Antenna Excluded)	
	IP	30	
	Certification	CE	

* Dependent on usage scenario

** Test under laboratory conditions and for guideline purposes only

Ordering Information

Part Number	Description
USM-S67-G20P0	USM-S67 LoRaWAN & LTE(EU) Gateway 915

Packing List

- 2 x Mounting Kits
- 1 x Type -C Cable
- 1 x USB Adapter

Dimensions

Unit: mm

